

High Pressure Compressor Type DM

Oil-free
compression

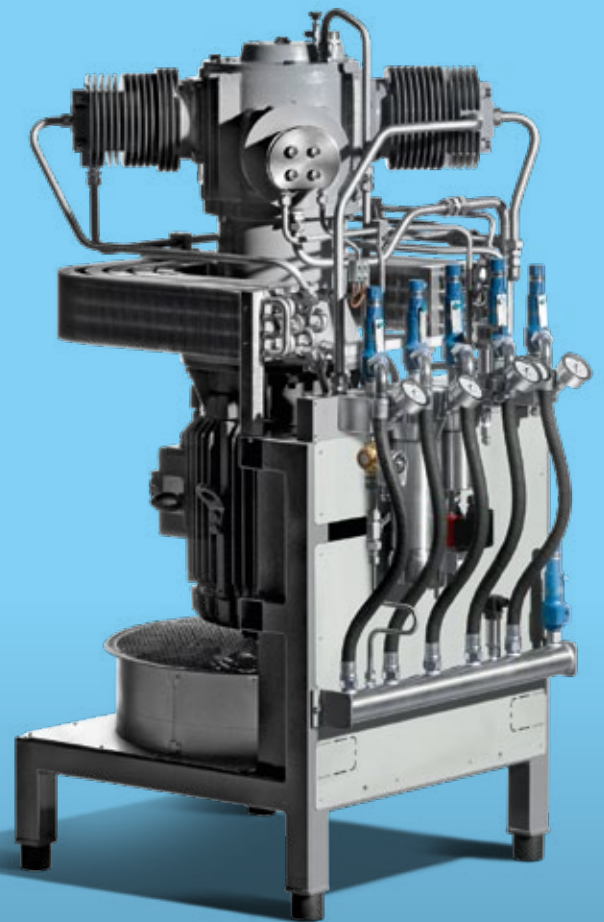

Atlas Copco with its GREENFIELD product range is your specialist for high-pressure systems. With a century of experience in this business we have been able to maintain and even improve our strong market position providing total solutions – from a single compressor to complete systems.

Today the GREENFIELD product range is the technology leader worldwide with its high-end premium products engineered in Switzerland.

With a century of experience in high-pressure technology and the fact of thousands of compressors installed worldwide, the GREENFIELD product range is ready to serve your needs for peak performance and success in the market.

Atlas Copco has global access to over 150 markets, which are served through our production facilities for high pressure compressor either in France, United States, India and China.

This comprehensive Sales and Service Network assures our customers direct access to the most reliable and technologically advanced equipment available.

Flow Rate Diagramm

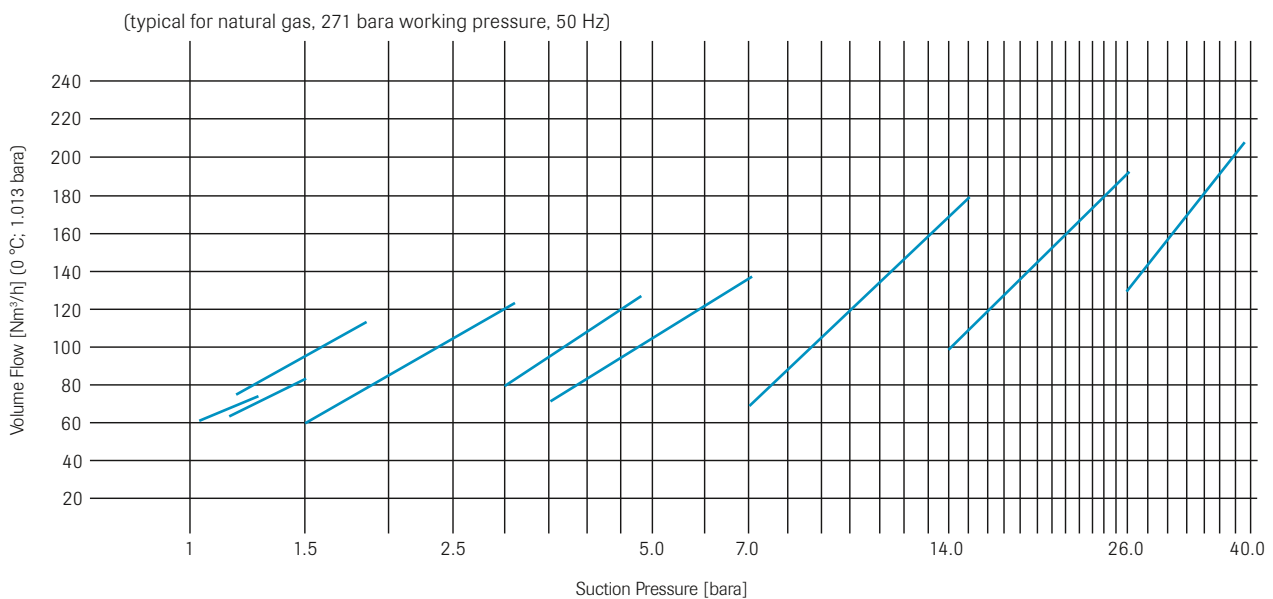

The DM Gas Compressor

The DM compressor range utilizes GREENFIELD's revolutionary oilfree high-pressure technology, which assures that oil neither contaminates the gas nor does oil disposal contaminate the environment. The hermetically sealed compressor-motor-unit with magnetic coupling ensures no gas losses to atmosphere. Due to the scotch yoke drive and antivibration pads the DM has a low vibration and

noise level. The vertical arrangement allows an installation in an area of 0.7 m² only. As the design for 2, 3, 4 or 5 stage units remains the same, the compressor blocks can be easily exchanged if suction pressure conditions or location of the installation changes.

Technical Data

Suction pressure:	up to 40 bara
Working pressure:	up to 450 bara
Flow rate:	up to 210 Nm ³ /h
Motor power:	30 kW (37 kW for D5M311.-GP)
Size:	900 x 740 x 1700 mm (L x W x H)
Weight:	approx. 800 kg
Gases:	Natural gas, processed biogas, hydrogen, noble gases, typical industrial gases, etc.
Applications:	CNG and hydrogen refuelling stations, bottle filling, breathing air, test and special applications, etc.

Dimensions

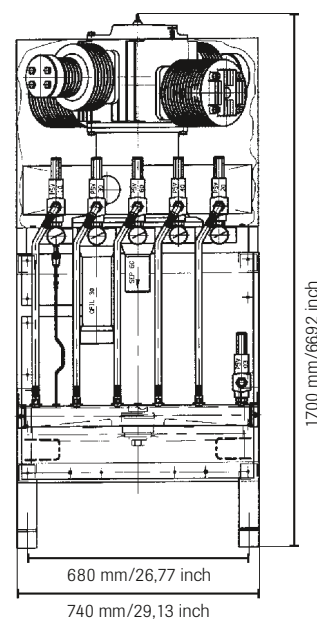
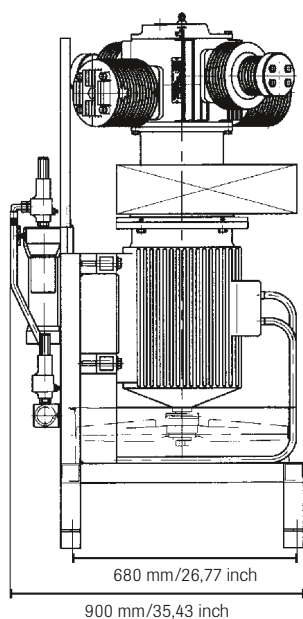

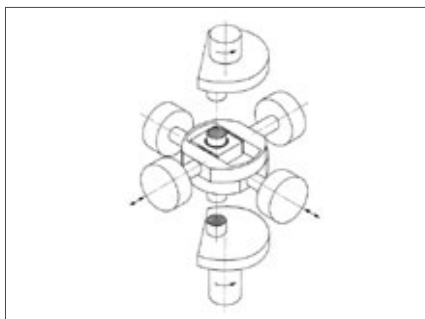

Standard Features

- 2 – 5 stage oil-free compression
- Frame-mounted unit with vertical arrangement
- Scotch yoke principle (balanced forces)
- Hermetically sealed crankcase
- Working pressures up to 311 bara
- Electric Motor drive with magnetic coupling
- Zone 2 classification
- Stainless steel tubing and interstage air-cooler
- Set of gauges and safety valves on suction, interstage and discharge side
- Pressure transmitter on suction and discharge side
- Temperature transmitter on discharge side
- Set of separators with automatic condensate drain
- Direct driven cooling-air fan
- Antivibration pads
- PED/ATEX conformity



Available Standard Options*

- Working pressures up to 450 bara
- Zone 1 classification (except D5M311.-GP)
- 3rd party inspection by TUV

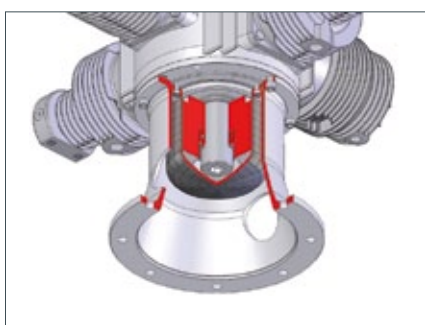

* Other non-standard options on request

The DM – All of the Benefits at a Glance:

- Low space requirements, reduction of construction costs thanks to small foundations
 - Highest reliability CNG compressor
 - Oil-free compression resulting in no oil carry-over into the gas, no additional costs for lubricating oil or its disposal
 - Ex-Zone 2 classification (TUV) due to compressor-motor-unit with magnetic coupling
 - No Methane emissions to atmosphere thanks to the hermetically sealed and pressure-tight crankcase
 - Low space requirements due to vertical arrangement
 - Extremely low vibration and noise level
 - Reduced power consumption due to utilisation of suction pressure
 - High efficiency, air-cooled
 - Low compression ratios in the individual stages, resulting in low wear and low thermal loads
 - Freedom from oil deposits means longer service life for valves and fittings
 - Long intervals between maintenance
 - Advanced maintenance concept for short downtimes
 - Low total costs of ownership
-



Atlas Copco



Sustainable Productivity

GREENFIELD
www.greenfield-comp.com

Part of the Atlas Copco Group

