Natural Gas Refuelling Station Type S750-SKID



GREENFIELD is your specialist for high-pressure systems. With a century of experience in this business we have been able to maintain and even improve our strong market position providing total solutions – from a single compressor to complete systems.

Today, GREENFIELD is the technology leader worldwide with its high-end premium products engineered in Switzerland.

With a century of experience in high-pressure technology and the fact of thousands of compressors installed worldwide, GREENFIELD is ready to serve your needs for peak performance and success in the market.

As part of the Atlas Copco Group GREENFIELD has global access to over 150 markets, which are served through our production facilities either in Switzerland or in the United States.

This comprehensive Sales and Service Network assures our customers direct access to the most reliable and technologically advanced equipment available.

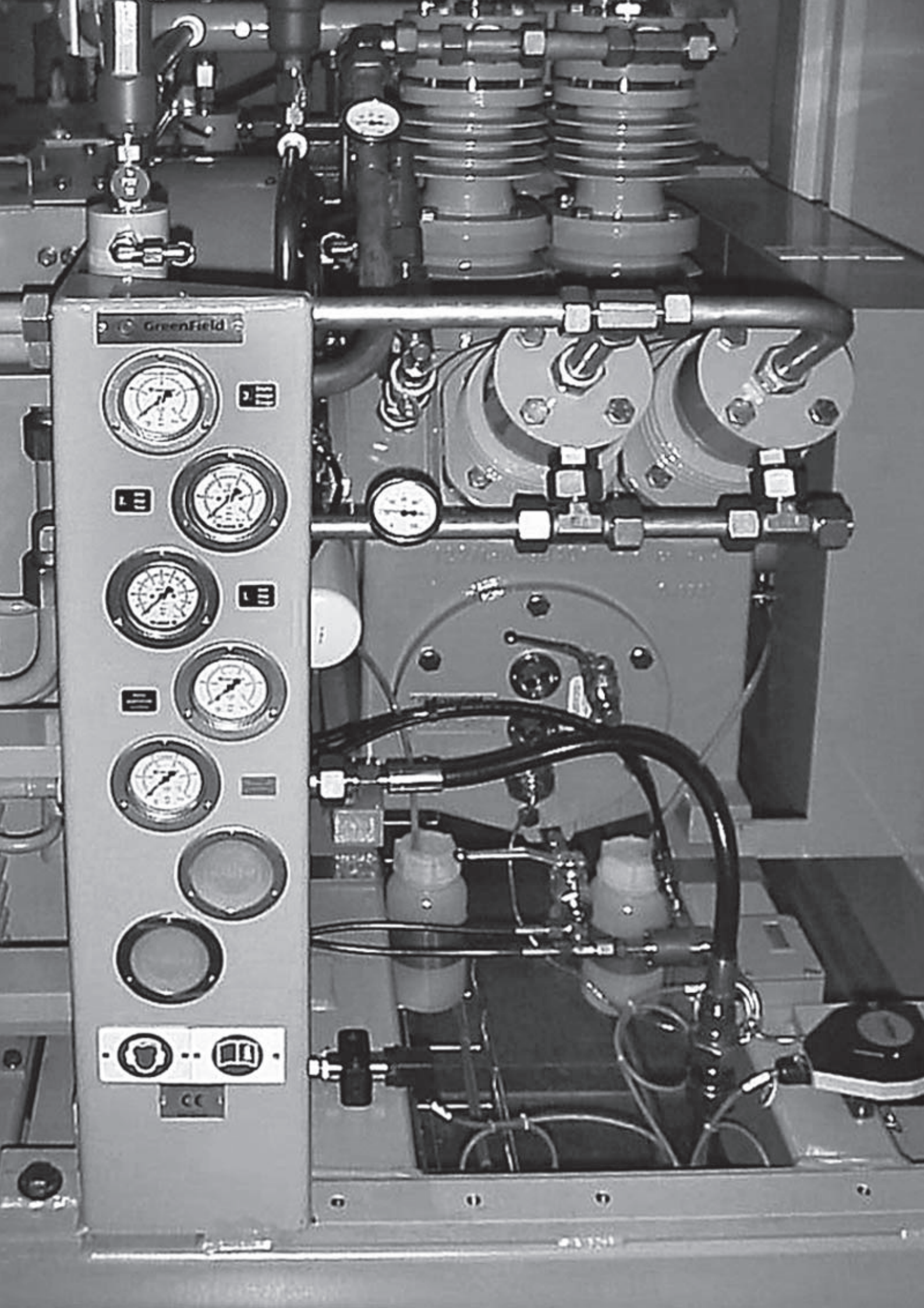

GREENFIELD offers the S750-SKID, an optimised CNG station, in a compact execution.

The S750-SKID refuelling stations are compact high-performance installations designed for the refuelling of cars and medium- to large-sized bus fleets with natural gas or processed biogas. Up to 450 cars, 45 buses or 90 trucks can be refuelled per day. All of the assemblies are clearly laid out on a skid with the option of a highly

accessible sheet metal enclosure with compact dimensions. Thanks to this compact design, you should be able to find room for the S750-SKID just about anywhere. The heart of this natural gas refuelling station is the CU compressor with its pressure-tight crankcase. As a result, there are no gas emissions to the atmosphere.

Key Parameters:

- Suction pressure: up to 18 bara
 - Capacity: up to 450 cars, 45 buses or 90 trucks per day
 - Delivery rate: up to 760 Nm³/h
 - Electric motor: 90/110 kW
 - Working pressure: 271 bara
 - Gas storage: max. of 40 gas cylinders (3 200 l, ~900 Nm³)
 - Sound level: 65 ± 3 dB(A) at 1 m acc. DIN/ISO 2151 (with enclosure)
 - Size: 4,17 × 2,09 × 2,92 m (S750-SKID)
3,20 × 2,09 × 2,20 m (Storage module)
 - Weight: approx. 6 tons (S750-SKID)
approx. 8 tons (Storage module)
-

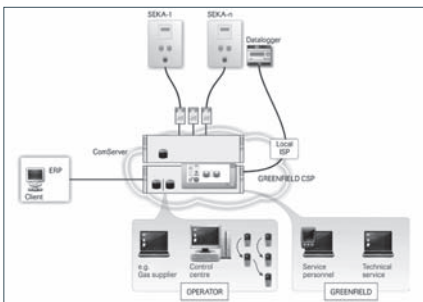
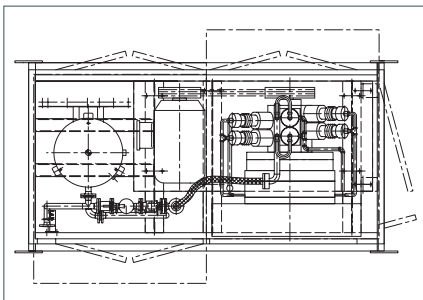
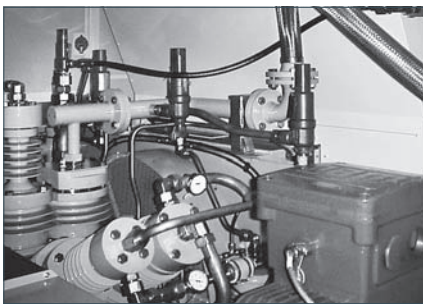

Standard Features

- Skid mounted unit
- Fully tested 3–5 stage CNG compressor, air-cooled
- Discharge pressure of 271 bara
- Electric Motor drive
- Inlet train with filter
- Outlet train with 3 line multifunction block for one fill hose
- Integrated Blow Down vessel for unloaded compressor start
- Control cabinet with electronic controller SEKA II (Installation outside enclosure)
- Star/Delta starter
- PED/ATEX conformity

Available Standard Options*

- Sheet metal enclosure
- Sound level 65dB(A) at 1 m acc. DIN/ISO 2151
- Lighting inside enclosure
- 24 × 80 or 40 × 80 litre storage module
- Inlet gas dryer (Installation outside enclosure)
- Dew point meter
- 3 line multifunction block for second fill hose
- Oil filter (≤ 10 ppmV)
- Gas sensor with or without analyzing unit
- Soft start or frequency converter
- Remote control/monitoring software SEMON
- CSP – Customer Service Portal allows monitoring of the station via internet with common browser, so no special software is required. Automatic error messaging via High-Priority-SMS or email included.
- UPS – Uninterruptible power source (autonomy approx. 1 h)
- 3rd party inspection by TUEV

* Other non-standard options on request.

Vehicle fillings per hour/day

(typical for natural gas at 18 bara suction and 271 bara discharge pressure)

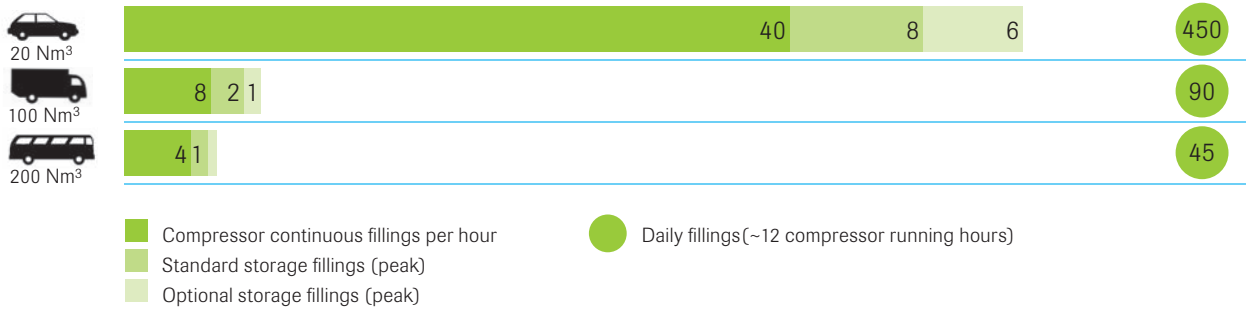

The CU Gas Compressor

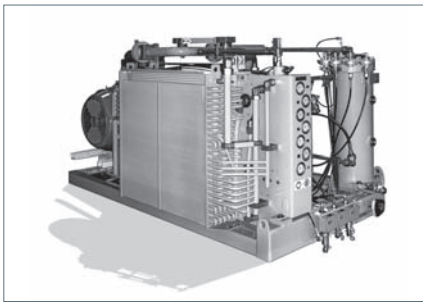

The air-cooled, lubricated trunk-piston compressor type CU offers field-proven ruggedness and reliability. Due to its simple and compact design the unit is space-saving and easy to maintain. The frame mounted compressor is bedded on vibration dampening elements and therefore requires no special foundation or factory erectors for its easy installation. Low compression ratios per stage allow high cylinder loads with comparable low temperatures. Results are high volumetric efficiency, low maintenance and more safety.

Flow Rate Diagram

(typical for natural gas, 271 bara working pressure, 50 Hz)

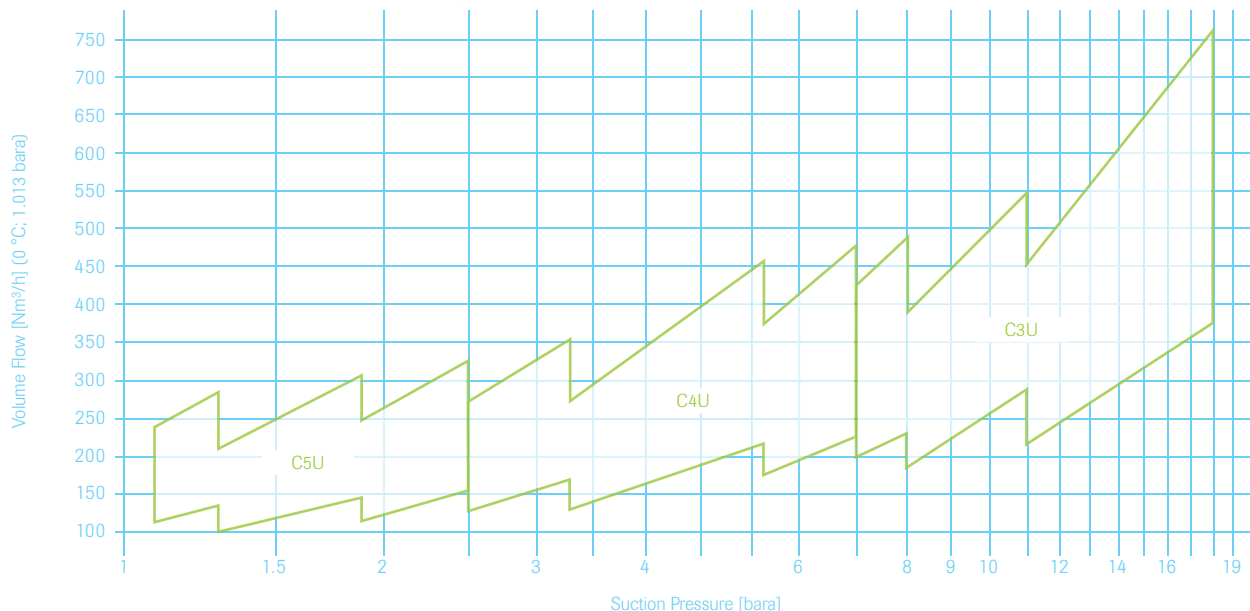

The S750-SKID – Benefits at a Glance:

- Low space requirements, reduction of construction costs thanks to small foundations
 - Highest reliability CNG compressor
 - Reduced power consumption due to utilisation of suction pressure
 - High efficiency, air-cooled
 - Low wear and low thermal loads resulting from low compression ratios in the individual stages
 - No Methane emissions to the atmosphere thanks to the pressure-tight crankcase
 - Long intervals between maintenance
 - Low total costs of ownership
-



GREENFIELD Europe
www.greenfield-comp.com

Part of the Atlas Copco Group

